

Utility Sink Model NOVUM





22

KUNe GmbH | Am Pregarten 23 | A-4240 Freistadt
 LE-Nr. PWB222104202
 EN 14688:2006

Utility Sink | Waschbecken | Evier | Lavabo | Fregaredo | Wastrog
 Model | Modell | Modèle | Modello | Tipo: NOVUM

Types | Typ | Tipi | Tipo : PWB22-60 | PWB22-80 | PWB22-100

[PH] Personal hygiene | Persönliche Hygiene | Hygiène personnelle | Igiene personale | Higiene personal | Persoonlijke hygiëne
 CL10

TABLE OF CONTENTS

CE-marking	2
Intended Use Misuse	4
Technical data	5
Intended Use Misuse	6
Scope of delivery general	7
Required mounting material	7
Bucket grid	10
Splash guard	11
Initial cleaning	12
Cleaning Frequency	12
Maintenance	12
Repair Spare parts	12
Disposal package sink	12
Dismounting	12
Initial cleaning	12
Cleaning Frequency	12
Maintenance	12
Repair Spare parts	12
Disposal package sink	12
Dismounting	12
What makes stainless steel rust resistant?	13
How to prevent rust	13
Cleaning stainless steel care	13
Homemade stainless steel cleaner	13
Powder coating what is it?	14
Cleaning Taking care of powder-coated surfaces	14
To prevent damage to coated surfaces	14
Repair	14
Liability limits	15

INTENDED USE | MISUSE

KUNe sinks are made of chrome-nickel steel with material number 1.4301. The steel falls under corrosion resistance class 2 and is excellently suited for sinks used in combination with a one tap fitting, such as in private areas (indoors and outdoors), in the food industry or in agriculture.

Typical use-cases are:

- ✓ hand washing,
- ✓ soaking, rinsing, washing out and washing down of objects,
- ✓ pouring out dirty water,
- ✓ filling buckets or watering cans.

Typical false use-cases are:

- ✓ filling with liquids that have moderate to high chlorine or chloride concentrations,
- ✓ pouring chemicals, sludge, clay, etc. without a suitable separator,
- ✓ filling of ash or other hot, glowing or burning or flammable media or objects,
- ✓ closing the overflow or deliberately using the overflow as a level limiter,
- ✓ using it to storage waste,
- ✓ using in the immediate vicinity or at sea (offshore) and in the immediate vicinity of a swimming-pool (pool technical room),
- ✓ using it to cleaning of electrical equipment (risk of electric shock),
- ✓ installing more than one tap fitting.

WARNING!



Check the product for sharp edges and danger of cutting:

- ✓ Before and after assembly,
- ✓ at regular intervals depending to the use of the product,
- ✓ after a damage event/damage.

If sharp edges are detected, refrain from using as well as cleaning the sink.

Sharp edges must be removed/repared immediately and exclusively by qualified personnel (e.g. metal technician).

When handling chemicals/cleaning agents, always observe the information in the safety data sheet/use information and wear appropriate protective equipment!

Always seek medical attention immediately after any accident.

NOTE!

The sinks are designed for a maximum load of 150 kg.

NOTE!

Chlorine, chlorides, highly concentrated acids or alkalise, vinegar, cement residue remover, etc. can permanently damage the surface of stainless steel.

NOTE!

When using liquids:

- ✓ above 85°C: Replace the siphon, overflow and drain valve with a resistant product.
- ✓ above 50°C: The glued anti-drumming mats may come off.

TECHNICAL DATA

Model NOVUM | Utility Sink

Types	PWB22-60		PWB22-80		PWB22-100	
Outer dimensions W _o xD _o xH _o [mm]	690 x 515 x 250		890 x 515 x 250		1090 x 515 x 250	
Inner dimensions W _i xD _i xH _i [mm]	600 x 350 x 220		800 x 350 x 220		1000 x 350 x 220	
Volume [l]	46		61,5		77	
Weight [kg]	14,50		17,4		20,30	
Aperture color	RAL 9017 black	RAL 9010 white	RAL 9017 black	RAL 9010 white	RAL 9017 black	RAL 9010 white
Type	PWB22-60-b	WBP22-60-w	PWB22-80-b	PWB22-80-w	PWB22-100-b	PWB22-100-w
Article number	PWB22-1001-B600-T350-H220-A300-RAL9017	PWB22-1001-B600-T350-H220-A300-RAL9010	PWB22-1001-B800-T350-H220-A400-RAL9017	PWB22-1001-B800-T350-H220-A400-RAL9010	PWB22-1001-B1000-T350-H220-A500-RAL9017	PWB22-1001-B1000-T350-H220-A500-RAL9010

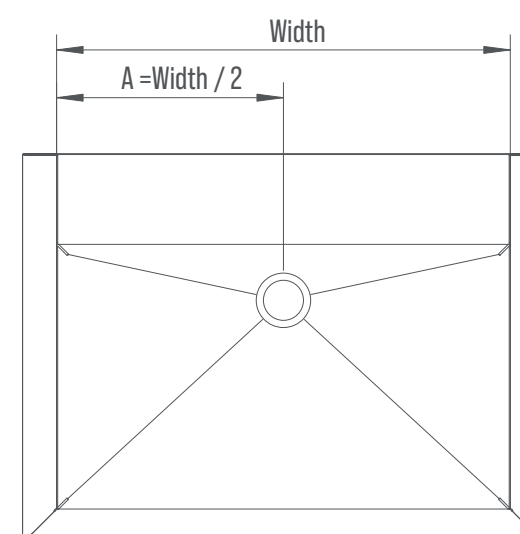
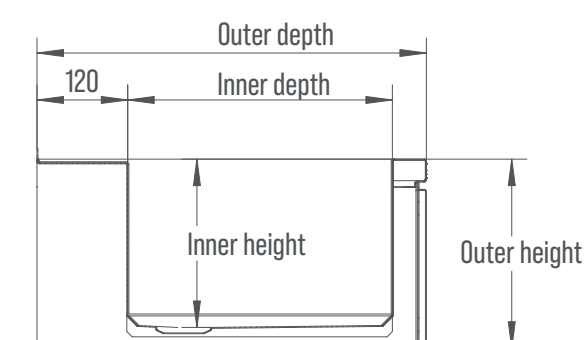
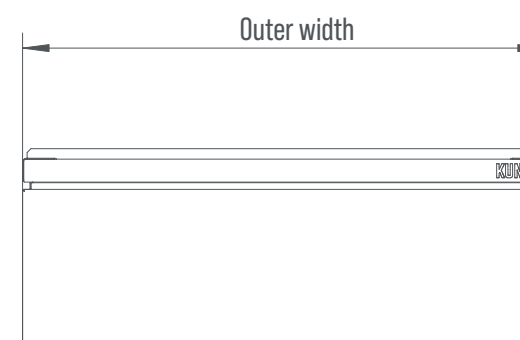

Technical design:

- ✓ Material 1.4301, inner surfaces ground K320, outer surfaces eccentricly ground
- ✓ Material thickness: forehead s=1,5mm, bowl s=1mm
- ✓ Width of bank for faucet = 70mm
- ✓ Support console - not necessary
- ✓ With overflow

INTENDED USE | MISUSE

KUNe sinks are made of chrome-nickel steel with material number 1.4301. The steel falls under corrosion resistance class 2 and is excellently suited for sinks used in combination with a one tap fitting, such as in private areas (indoors and outdoors), in the food industry or in agriculture.

Typical use-cases are:

- ✓ hand washing,
- ✓ soaking, rinsing, washing out and washing down of objects,
- ✓ pouring out dirty water,
- ✓ filling buckets or watering cans.

Typical false use-cases are:

- ✓ filling with liquids that have moderate to high chlorine or chloride concentrations,
- ✓ pouring chemicals, sludge, clay, etc. without a suitable separator,
- ✓ filling of ash or other hot, glowing or burning or flammable media or objects,
- ✓ closing the overflow or deliberately using the overflow as a level limiter,
- ✓ using it to storage waste,
- ✓ using in the immediate vicinity or at sea (offshore) and in the immediate vicinity of a swimming-pool (pool technical room),
- ✓ using it to cleaning of electrical equipment (risk of electric shock),
- ✓ installing more than one tap fitting.

WARNING!



Check the product for sharp edges and danger of cutting:

- ✓ Before and after assembly,
- ✓ at regular intervals depending to the use of the product,
- ✓ after a damage event/damage.

If sharp edges are detected, refrain from using as well as cleaning the sink.

Sharp edges must be removed/repared immediately and exclusively by qualified personnel (e.g. metal technician).

When handling chemicals/cleaning agents, always observe the information in the safety data sheet/use information and wear appropriate protective equipment!

Always seek medical attention immediately after any accident.

NOTE!

The sinks are designed for a maximum load of 150 kg.

NOTE!

Chlorine, chlorides, highly concentrated acids or alkalise, vinegar, cement residue remover, etc. can permanently damage the surface of stainless steel.

SCOPE OF DELIVERY GENERAL

1 piece
Drain valve with overflow

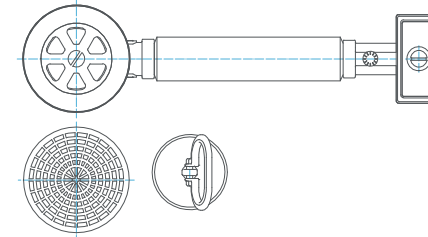

1 piece
Bottle siphon

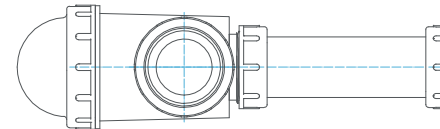

1 piece
Cylinder head screw M6x25 for overflow



7 pieces
Self-adhesive pads for noise reduction

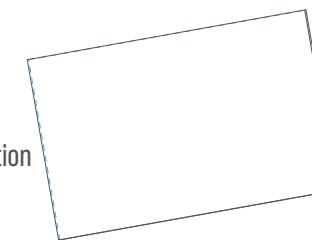

4 pieces
Threaded rod M8x110 with washer, nut and DN12x80 screen case



1 piece
Composite mortar cartridge 300ml with static mixer

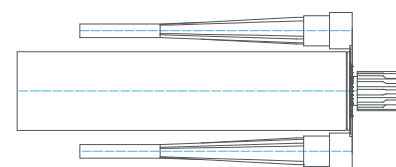

12 pieces
Clip (for aperture mounting)



REQUIRED MOUNTING MATERIAL

- ✓ pencil
- ✓ tape measure
- ✓ spirit level
- ✓ hammer drill
- ✓ masonry drill 12mm
- ✓ hammer
- ✓ combination wrench SW13
- ✓ slotted screwdriver large
- ✓ allen key 5mm
- ✓ caulking gun
- ✓ borehole blower and round wire brush DN12

NOTE!

Check the building structure's static suitability! The supplied mounting material is suitable for:

- ✓ Non-cracked concrete (C20/C25)
- ✓ Solid brick (SFK=12)
- ✓ Vertically perforated brick (Hlz12=1.0 kg/dm³)
- ✓ Aerated concrete (PB4) - only when installing using adhesive anchors!

Use a soft base during installation to avoid damage and scratches.

CAUTION!

The assembly should only be carried out by qualified personnel.

When marking the holes and fixing the sink should be done by two people.

WARNING!

Protective equipment required!

This can include safety goggles, hearing protection, safety shoes, cap/hair net, gloves, etc.

When working with rotating tools such as angle grinders or drills:

- ✓ wear a cap/hair net.
- ✓ do **not** wear gloves.

NOTE!

When using liquids:

- ✓ above 85°C: Replace the siphon, overflow and drain valve with a resistant product.
- ✓ above 50°C: The glued anti-drumming mats may come off.

1. position sink

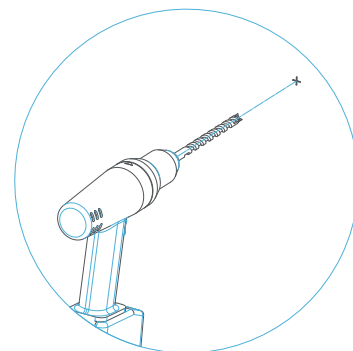
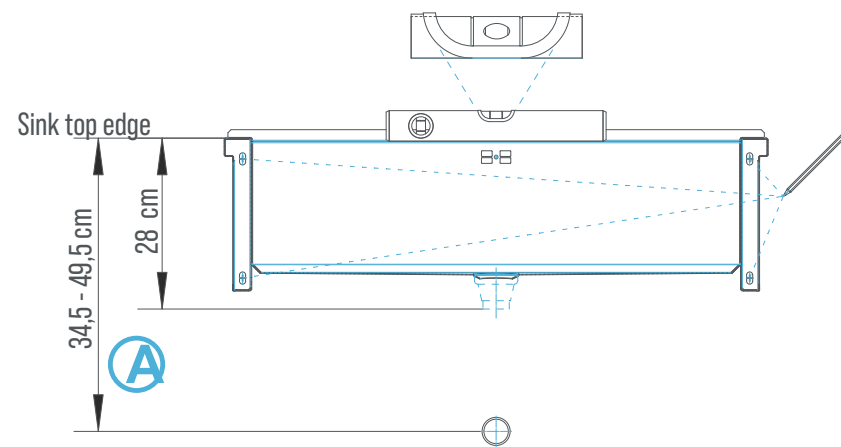

12mm drill diameter, min 7cm deep
2x blow out drill hole and clean with the wire brush.

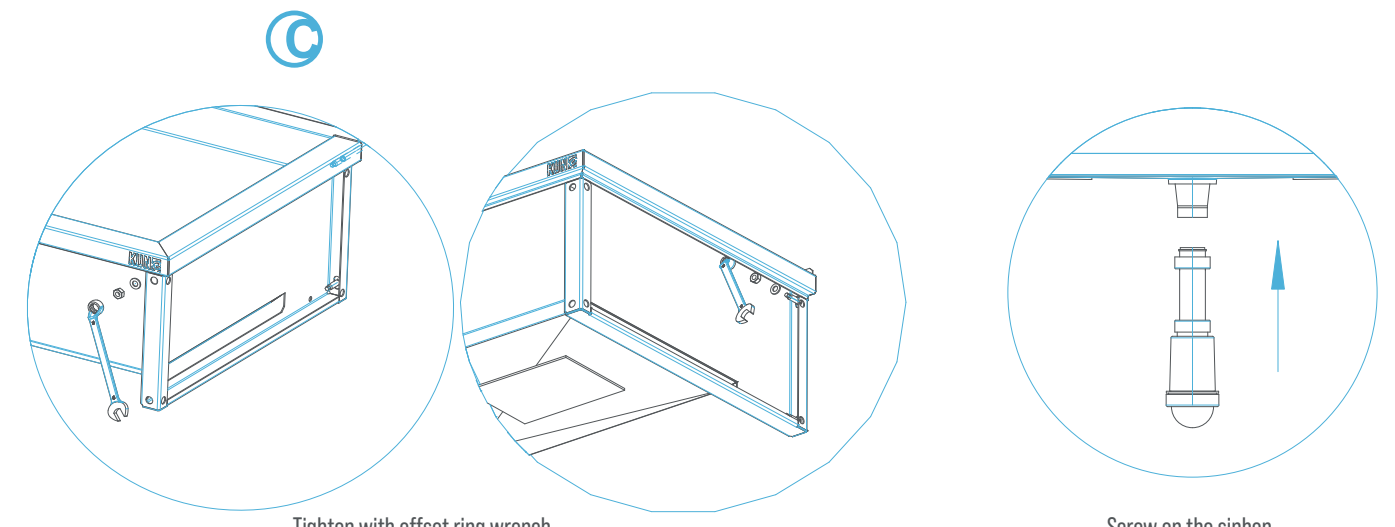

Tighten with offset ring wrench

Screw on the siphon

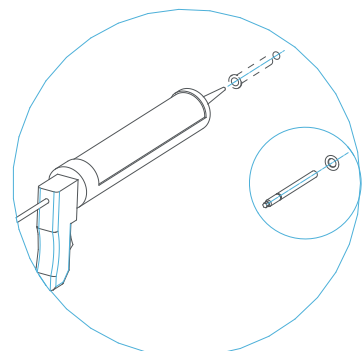

Please observe the instructions for processing of the composite mortar on the adhesive cartridge.

The adhesive anchor must not protrude more than 30 mm from the wall protrude from the wall.

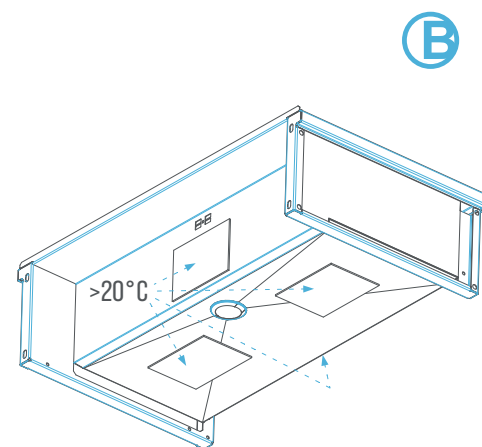

To make sure the pads stick well:
- The pads must be at least at room temperature.
- The surfaces must be free of grease.

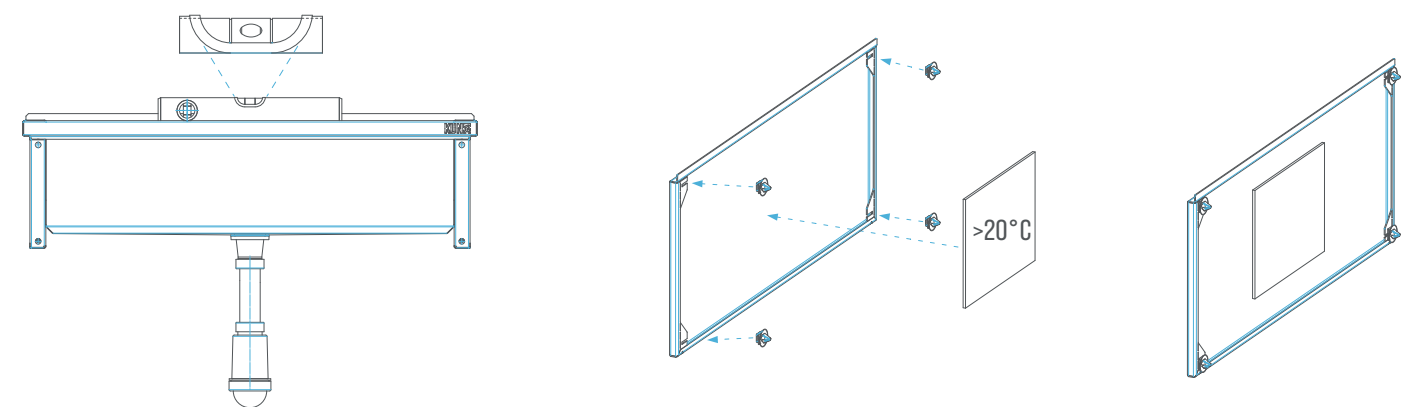

Check slope and correct if necessary.
No accessibility after orifice assembly).

1. glue pads inside
2. install clips in panels

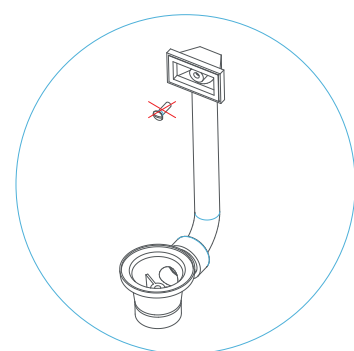

Discard the slotted screw with countersunk.

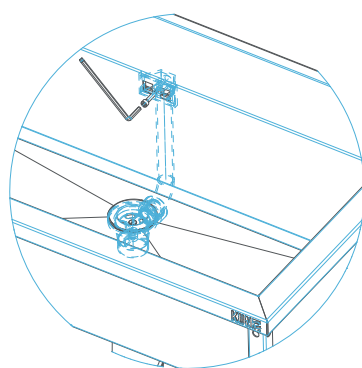

Screw on the overflow with M6x25 cylinder head screw (allen screw)

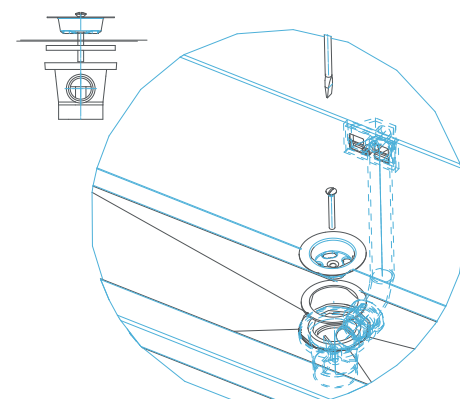

Screw the drain strainer to the drain valve

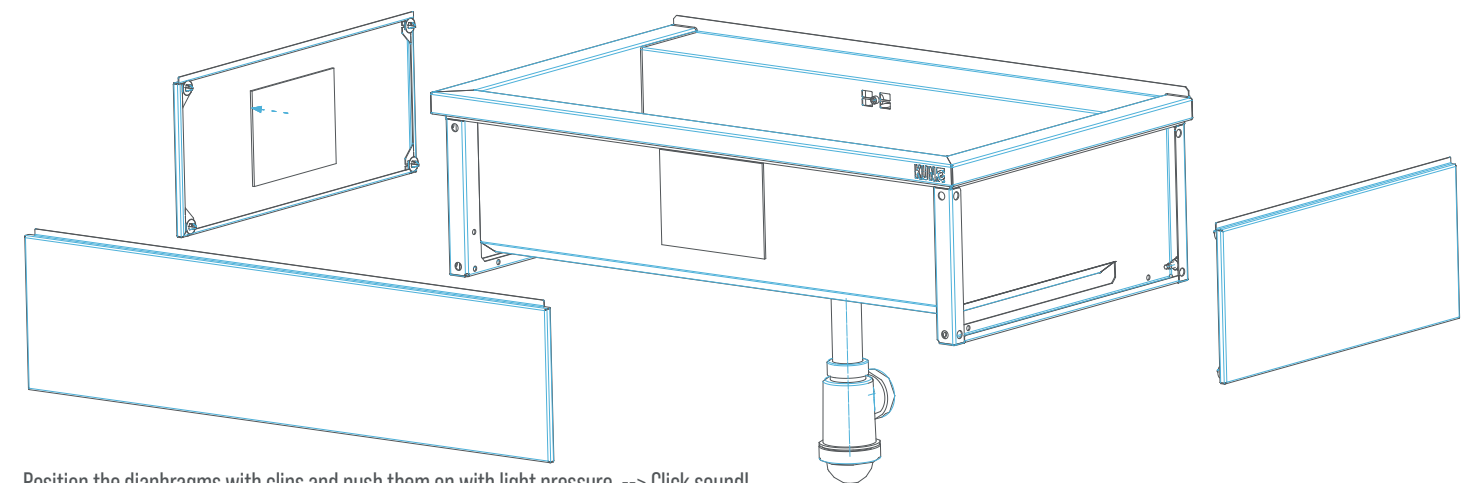

Position the diaphragms with clips and push them on with light pressure. --> Click sound!

A

These dimensions only apply to the plastic siphon included in the standard scope of delivery!
(If required, the down pipe can be extended with a DN40 HT pipe).
If you use a different siphon, please refer to its dimension sheet.

B

We recommend to cut a hole in the basin for the fitting.

C

We recommend to mount the splash guard here.

BUCKET GRID

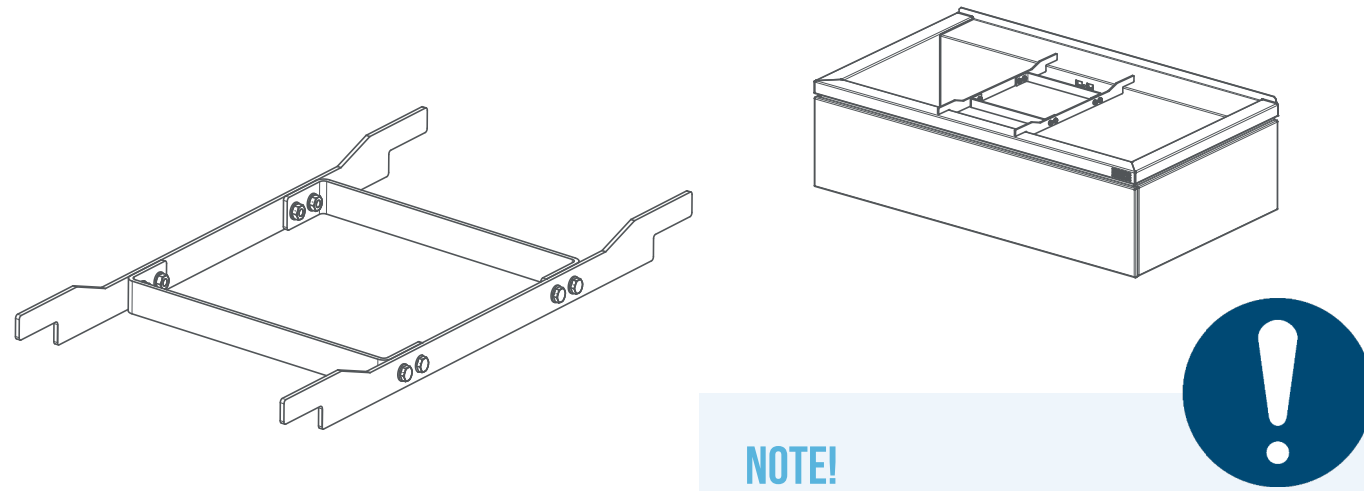

NOTE!

The maximum load of the bucket grid must not exceed 25kg!

Type	Item number	Width [mm]	Depth [mm]	Weight [kg]	Surface
WB15-KR	WB15-1004-T350xB200	216	426	0,75	Stainless steel ground on both sides K320

SPLASH GUARD

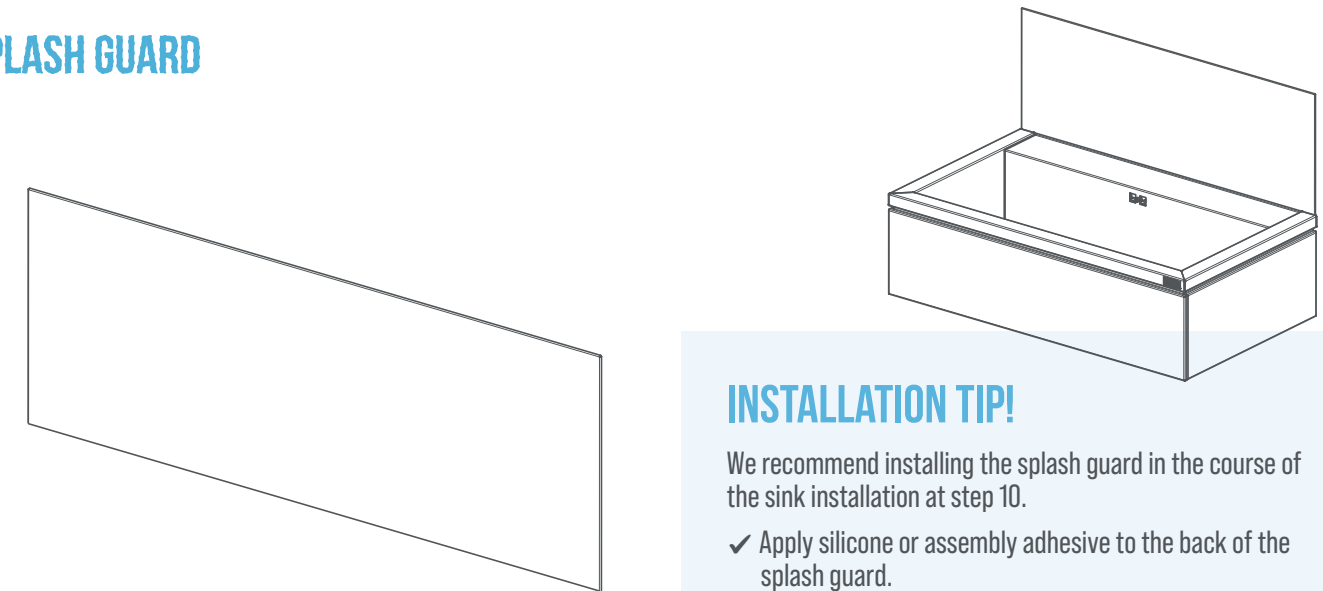

INSTALLATION TIP!

We recommend installing the splash guard in the course of the sink installation at step 10.

- ✓ Apply silicone or assembly adhesive to the back of the splash guard.
- ✓ Place the splash guard on the sink.
- ✓ Press the splash guard against the wall and keep it stabilised until adhesive has solidified.

Type	Item number	Width h [mm]	Height [mm]	Weight [kg]	Surface
PWB22-SP60-K320	PWB22-1008-B600xH300-K320	682	300	1,77	Stainless steel ground on one side K320
PWB22-SP60-RAL9010	PWB22-1008-B600xH300-RAL9010	682	300	1,87	Powder coated RAL9010 white, fine structure matt
PWB22-SP60-RAL9017	PWB22-1008-B600xH300-RAL9017	682	300	1,87	Powder coated RAL9017 black, fine structure matt
PWB22-SP80-K320	PWB22-1008-B800xH300-K320	882	300	2,27	Stainless steel ground on one side K320
PWB22-SP80-RAL9010	PWB22-1008-B800xH300-RAL9010	882	300	2,37	Powder coated RAL9010 white, fine structure matt
PWB22-SP80-RAL9017	PWB22-1008-B800xH300-RAL9017	882	300	2,37	Powder coated RAL9017 black, fine structure matt
PWB22-SP100-K320	PWB22-1008-B1000xH300-K320	1082	300	2,76	Stainless steel ground on one side K320
PWB22-SP100-RAL9010	PWB22-1008-B1000xH300-RAL9010	1082	300	2,77	Powder coated RAL9010 white, fine structure matt
PWB22-SP100-RAL9017	PWB22-1008-B1000xH300-RAL9017	1082	300	2,77	Powder coated RAL9017 black, fine structure matt

INITIAL CLEANING

Due to production, packaging, transport, assembly, etc., unwanted impurities may get into the sink no matter how carefully it is handled. Therefore, the sink should be cleaned after it has been assembled and before first use.

Please carefully read our care tips!

CLEANING FREQUENCY

Regular cleaning is important! Clean the sink with suitable cleaning agents. The frequency that sink maintenance should be carried out depends on the frequency of use.

MAINTENANCE

Check at regular intervals adapted to the use, but at least once a year for:

- ✓ mechanical damage and sharp edges, 
- ✓ corrosion of the sink and in particular the condition of the fastening screws,

REPAIR | SPARE PARTS

All our sinks are repairable.

This means that the material are thick enough to be welded and repaired by a metal engineering company using the TIG welding method.

If you need spare parts such as screws, drain valve, anti-drumming mats or facing elements, please write us at service@kune-online.com

DISMOUNTING

Proceed as follows:

- ✓ Remove all accessories,
- ✓ follow the the mounting instruction steps in reverse order.

DISPOSAL PACKAGE | SINK

Breathe new life into our products and packaging materials by taking them to your nearest recycling collection point. Most of the materials we use can easily be recycled. This is especially true of the stainless steel we use which is a valuable raw material and can be recycled several times.

Thank you for protecting our environment!



NOTE!

Cover the sink to protect it from contamination on the construction site!



NOTE!

Incipient corrosion and flash rust should be removed immediately!

- ✓ check the overflow function (if any) and the drain,
- ✓ remove suspended matter / deposits from the siphon,
- ✓ check the tightness of the inlet and outlet pipes.

- ✓ Repair any defects found immediately or promptly, depending on their severity,
- ✓ have repairs carried out by a specialist company in your area,
- ✓ sharp edges should only be removed by a specialist company.



WARNING!

Take note of the warnings in the assembly instructions

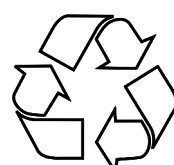

WHAT MAKES STAINLESS STEEL RUST RESISTANT?

Stainless steel forms a so-called passive layer. Although the passive layer is only a few atomic layers thick, it provides the material with excellent protection against environmental damage. The passive layer is also called a barrier layer. It forms independently under normal conditions (contact with air and water) and protects the material from corrosion. The barrier layer is self-healing. If it is damaged/scratched, in normal conditions it will form again by itself.

ADVANTAGES OF STAINLESS STEEL

- ✓ Easy to clean, as dirt and grease can be easily washed off,
- ✓ odourless - does not absorb odours,
- ✓ 100% recyclable and UV-resistant,
- ✓ easy to repair,
- ✓ our stainless steel sinks don't rust when used properly.

HOW TO PREVENT RUST

- ✓ Clean the sink after contact with iron objects (ferritic objects) such as spades, trowels, cans, etc.,
- ✓ do not leave ferritic objects on/in the sink for a long time, this will cause rust rings. Iron deposit will start to build on the stainless steel surface and this iron will start to rust,
- ✓ do not clean the sink with a scouring pad, scouring powder, potting sponges, wire mesh or similar,
- ✓ remove any droppings, such as from from birds, regularly and at short intervals.

CLEANING | STAINLESS STEEL CARE

- ✓ After each use, clean the bowl with a little washing-up liquid,
- ✓ clean with a stainless steel cleaner such as PlanB Citrus Cleaner regularly. Rinse the sink with sufficient water afterwards,
- ✓ in the case of heavy soiling and permanent flash rust stains, then we recommend cleaning the stainless steel intensively, using a product such as PlanB Stainless Steel Restorer. Rinse afterwards with sufficient water,
- ✓ the two cleaning agents mentioned above have been tested on our sinks by an independent technical office. They can be purchased via our webshop: www.kune-online.com.

HOMEMADE STAINLESS STEEL CLEANER

Use sodium bicarbonate for streaks and fingerprints

Mix three tablespoons of baking soda (available in grocery stores) with one tablespoon of water to make a paste and rub the affected areas.

Use vinegar for lime stains

Mix three parts water with one part vinegar essence.

Caution: Undiluted, concentrated vinegar will permanently destroy the stainless steel surface!

Use citric acid for lime and rust stains

Dissolve three tablespoons of citric acid powder (available in grocery stores) into one litre of water and leave the solution on the affected areas for 1-2 hours.



NOTE!

Brushed stainless steel surfaces must be cleaned in the direction of grinding. Only use soft and clean cloths for this purpose!



NOTE!

Chlorine, chlorides, highly concentrated acids or alkalies, vinegar, cement residue remover, etc. can permanently damage the surface of stainless steel.

The sink must be rinsed with plenty of clear water after each use and after each cleaning and, if necessary, wiped with a dry cloth.

POWDER COATING WHAT IS IT?

A powder coating is a particularly versatile and high-quality surface coating. Facades, bicycles, machine cladding and pieces of furniture such as garden furniture, umbrella stands and many more are often coated. The components that are coated are first electrostatically charged and then sprayed with fine plastic powder. This powder adheres to the components due to the electrostatic charge. This powder layer is then melted in a baking oven at a temperature of around 140-200°C. In this process, the powder coating forms a firm bond with the component and begins to get its typical powder coating appearance typical as well as a closed and high-quality protective layer. All our KUNe products only use plastic coating from quality manufacturers who offer quality facade coatings with high UV resistance. The coating is not only UV-resistant, but also easy to clean, reduces fingerprints, and gives the surface a silky matt design.

CLEANING | TAKING CARE OF POWDER-COATED SURFACES

- ✓ After use, wipe coated surfaces with a clean and damp cloth.
- ✓ Add a little dish washing detergent for any stubborn stains.

Allow any clumps of soil to dry and remove them as gently as possible (e.g. with your fingers). Avoid wiping or abrasive movements. After removing them, use a clean and soft cloth to wipe.

TO PREVENT DAMAGE TO COATED SURFACES

- ✓ Avoid scratches and abrasive contact with hard objects. For example, do not lean bicycles against a sink with coated panels.
- ✓ Avoid wearing clothing with rivets, buttons or avoid contact when working on a sink.
- ✓ Do not clean the sink with a scouring pad, scouring powder, potting sponges, wire mesh or similar.
- ✓ Remove any droppings, such as from birds, regularly and frequently.

REPAIR

- ✓ Small scratches can be repaired with a repair kit available from specialist dealers or a touch-up pen,
- ✓ in the case of more serious damage, you can also purchase individual panels from us. To order them, please write to us at service@kune-online.com



NOTE!

Even short contact with products such as nitro thinner or acetone will permanently damage the surface of the powder coating!

Also avoid alkaline, acidic, abrasive or other cleaning agents that may damage the coating.

Use only soft and clean cloths during cleaning.

Do not use steam jet equipment or high-pressure cleaners for during cleaning.

LIABILITY LIMITS

We accept no liability for any damage and malfunctions resulting from failure to follow the operating instructions/information on the products use. The text and graphical representations do not necessarily correspond to the scope of delivery and are not to scale. The actual scope of delivery may differ from the information and notes described here as well as the graphical representations in the case of special versions, the use of additional order options or due to the latest technical changes.

If you have any questions or suggestions for improvement, please contact:

service@kune-online.com

We reserve the right to make technical changes to the product within the scope of improving the product and for further development.

For ease of reading, no gender-specific distinction is made (e.g. male/female). Corresponding terms in the text refer in principle to both genders in the sense of the Equal Treatment Act (in accordance with Austrian law: Gleichbehandlungsgesetz-GIBG, BGBl. No. 66/2004).

This document is protected by copyright and is for the exclusive use of the owner of the product.

Any duplication or use, communication and/or transmission of its contents in whole or in part is not permitted without the author's written consent. Violations obligate to compensation. Further claims remain reserved.

Typesetting and printing errors excepted.

Media owner and publisher

KUNe GmbH

Am Pregarten 23
4240 Freistadt
Austria

service@kune-online.com
kune-online.com

Manufacturer/Printer
DOWNLOAD Version

